

Part Three
The Universe on Ketamine:
A personal journal documenting ketamine mindscapes
By
Willard G. Van De Bogart
(Entries from Nov 1978 – July 1983)

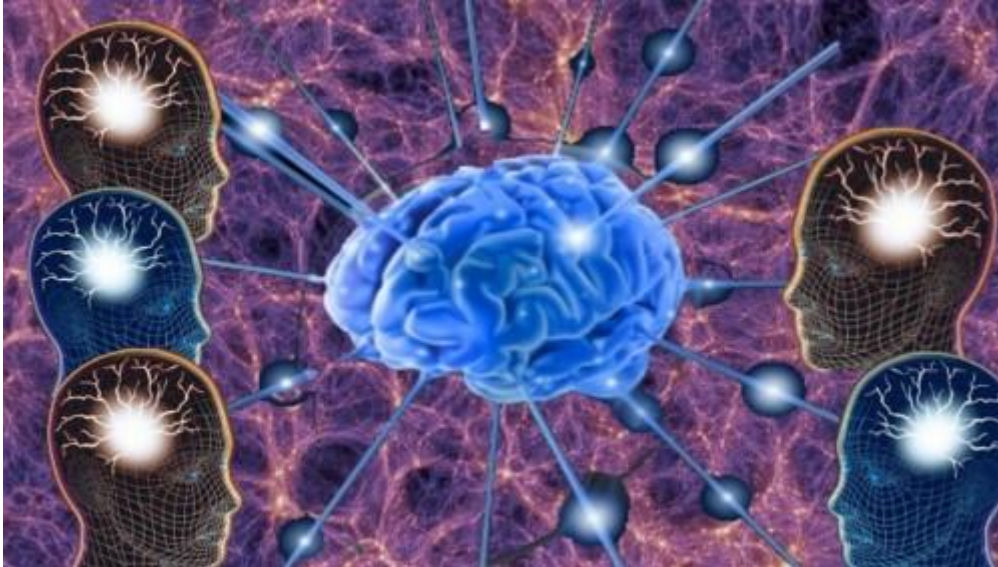

March 3, 1983 - 9:40 p.m. 50mg S.F. CA - (51st injection) Pgh. PA.

I have put the Poem of Ecstasy Opus 154 by Scriabin (<http://www.youtube.com/watch?v=BWINpXNd5KE>) on the tape player. I am now awaiting the K. experience since my last experience in Pittsburgh. I feel very quiet and confident of my using K. I realize I am willing to seek out something that the mind provides. I had a large meal this evening consisting of baked chicken with peaches, potatoes and broccoli with some wine. I am now ready to introduce myself to this new environment, which I arrived in on February 14th 1983. I am presently planning the mind parlor concept which will be an opportunity to explore the mind and to share these experiences with others. Our uniqueness as humans is evident, and it is this K which enables me to feel a new world opening before me.

March 3, 1983 - 11:40 p.m. 50 mg S.F. CA. (52nd injection)

With the last dosage I became very warm and enjoyed the music selection of Scriabin and then I rested for about two hours.

I got up and did another 50 mg to feel my world for the 2nd time. This time I am in my bedroom. I believe this is a good environment to explore with K. With the 2nd injection I transit into sleep very easily. These two K experiences acted as an introduction to the worlds on K which I have become familiar with. Again the movement quality which transpires on K. is difficult to express in words. The feeling gained was pleasant and I believe the personalized Mind Parlors will be successful.

March 4, 1983 - 5:30 p.m. 50mg S.F. CA. (53rd injection)

I had a light meal at 1:00 p.m. It's very quiet now. Its daylight and I want to feel K at this time. I am alert and have accomplished a lot of work today. I am sitting in the living room. Without any music ••• just thoughts. I think its best to do small introductory amounts of K as a way of familiarizing one self with the effects of K. The need to feel this psychic motion is important to me. It is very relaxing and now at 5:35 p.m. I can feel the K coming into my world. It's an addition to the reality I am in. a new level of participation and a way of becoming united with energy fields. I believe this is a good. A very good life is here in San Francisco as a nodal point of activity. A new nation ••• but more a new Wave, a flow of friends in time to discuss their lives and attitudes.

March 4, 1983 - 6:12 P.M. 30 mg booster S.F. CaA (54th injection)

I think this 30mg booster will be fine. I am playing Pauline's music, drinking a little wine and looking forward to the K. 45 min. have passed so 30mg went in at 6:25 p.m. almost an hour. This time a small amount just to see if there is an effect. The Contact Network is on my mind. Attitude is the key. But what is an attitude? (a state of mind). A way to explicate yourself into the world. And now at 7:18 p.m. I am preparing to go to the Contact Network party in town.

March 5, 1983 - 1:55 a.m. S.F. CA. 60mg (55th injection)

After an evening of dancing and not drinking any alcoholic beverages I have decided to go into a deep sleep with K. Usually I do not remember these transitions and this was no exception. So I feel if you want to sleep, this way is a guaranteed way to do it. However, if you want to have the mental experiences you have to be alert. Also the 60mg did not seem to be quite enough to feel the other dimensional experiences. I met a woman writer at the Contact Network writing a book based on a poem by William Blake which was about her experiences with men around the world. The poem was "To kiss the joy of love on a wing goodbye." She is quite creative am very dedicated to her craft. I am going to send her some of my writings and a tape of Pauline Strom. So the Contact Network provided a contact; Rebecca Bruns.

March 5, 1983 - 5:38 p.m. 100mg - S.F. CA. (56th injection)

It is time to see the motion I have experienced in the past. The dosages I have been taking thus far have not enabled me to have those experiences. Today I put back into working order my light display GSR bio-feedback unit. I also prepared the material for the Mind Parlors. The classified ad is now complete for the Whole Life Times. At 5:54 p.m. I had a fine injection. This should provide what I have been looking for since I have been eating lightly. I had a glass of milk and a piece of bread with some peanut butter. The time is now 6:28 p.m. and I find myself writing. This dosage has enabled me to be unlike any of the other experiences. I came out of this very pensive

as if some larger reality made itself known to me, but I am unable to describe it. I was not physically upset, nor did I feel any unusual effects. I just knew I had experienced something different. It was as though I did not even take any K. The experience was so complete that distinctions were not made between this normal reality and the K reality. Later in the evening I began to read further "The Scientist" by John Lilly.

March 5, 1983 11:40 p.m. 100mg S.F. CA. (57th injection)

Due to this unresolved mood from the last 100mg, and since I have been reading "The Scientist" by Lilly for the last two hours. I am once again going to see if the same experience comes about. I am familiar with the experience and have developed a new curiosity to this exploration.

After this wore off I was aware of the totality of the experience revolving around the profound existence of the life force. How this force integrates itself into the world is at present the level I am working on. Belief systems are the areas being dealt with.

March 6, 1983 - 3:00 p.m. 40 mg S.F. CA - (58th and 59th injection)

This time only a small dosage was administered so that I could communicate ideas to another member of Ether Ship productions. He only weighs 115lbs and has a very high metabolism. Usually this affects him quite a lot and he tends to go into his mind. The last time he experienced K. was in May of 1982. This was the setting where I was first administering my first injection with a nurse. The motivation to do this was a business level with ideas flowing from a K. space. We were trying to express the mental attitude with K. and translate these ideas into the record production company. He experienced a very warm feeling and expressed ideas that every thing was going well. He was less concerned with the toils of the day and felt quite good. He was nodding off into his mind so I had to keep talking to prevent this.

Around 5:00p.m. I took a 20mg (59th injection) and walked outside to go to a Chinese eating place. It was raining but I did not feel the rain very much and I was able to walk quite well.

March 7. 1983 Comment on reading "The Scientist" by John Lilly

This morning I am reading about Lilly's documentation with K. and studying his dosage charts and they describe experiences very similar to my own. His feelings about a Solid State Culture have been a view of mine for many years. I do not feel I have made contact with any extraterrestrial agents, but then I have not taken 150mg's or more. I have found "The Scientist" by Lilly to be an incredible personal documentation of a great deal of work and a personal view point about Earth Coincidence Control Center as well as a Galactic Coincidence Control Center and the Cosmic Coincidence Control Centers". This was a new concept for me. I could appreciate Lilly's dosage charts. To date I find that my experiences are not the same, but I do find that journeys into these spaces are leaving me with a deep sense of curiosity about the vast unseen world of the Mind.

March 8, 1983 - 10:30 p.m. 100mg - S.F. CA (60th injection)

This evening I am going to do another 100mg. I think it is a good time. It's later than the 1st 100mg on March 5th, but earlier than the 2nd dosage. The experience could be

quite different or the same. It was a perfect entry. I look forward to this new level of K. This is the 4th time with 100mg. After this experience all I can say is; I vanished. The imagery was so intense I could not imagine it was me that was actually going through this. It is quite impossible to describe. All I know is that I was in some sort of light environment and then all of a sudden I moved with it. I have no idea where it was going.

March 9, 1983 - 8:00 p.m. 20 mg S.F. CA - (61st injection)

This was done for a general relaxation. I made some telephone calls. I called Lora Breed who I dated from New Years 1982 until late April 1982 very steadily. I called from the Marina as I was living on Beach Street. At this point I needed a change so I went over to visit her. I had to talk to someone in person and forget this research for a while.

March 10, 1983 - 11:00 p.m. 50mg S.F. Ca. (62nd injection)

I tried to gain some sort of motion again but as usual I went directly to sleep.

March 11, 1983 - 7:00 p.m. 30mg S.F. CA (63rd injection)

This time I drafted a full hot tube of water and relaxed in it. I felt very warm as the K took effect. This was by far the most relaxing experience I have ever had. I felt warm and I began to recall the Chinese girl I met earlier in the day. I remembered her eyes. I felt a hypnotic energy in my body as I remembered her eyes and felt as though our two bodies fused together. This was a new sensation.

March 15, 1983 - 10:00 p.m. - 85mg S.F. Ca. (64th injection)

This evening I am tired from working in the day, but my need to once again look at these patterns of the mind necessitates taking some Ketamine. A new booklet has been put together called, "Paths of the Mind". This is in preparation for the Mind Parlor seminars. For me at this point I wonder how best to understand the properties of human consciousness. This evening I have reduced the mg dosage to 85mg since 100mg seems to peak out of my realm of participation. I feel good about doing this experience. At this point, after this experience was over, I do not think being tired is conducive in taking advantage of the unique sensations Ketamine provides with its visual imaging capabilities. To be rested, yes, along with a clear mind preferably before 8 p.m. and perhaps early in the day. This experience was very pleasant, but again the transition into sleep prevented my coming back and recalling the experience faithfully.

1983 8:00p.m. 70mg with a 30mg booster at 10:00p.m.. S.F. CA - (65th & 66th injections)

This evening I have come to the conclusion that I should take Pemoline along with Ketamine to maintain an active awareness after the Ketamine is over. This evening I will take 70mg since the 85mg was pushing me into sleep and I'd like to write

something about my experiences. I have prepared a 30mg amount so when the 70mg has worn off I will have a booster ready to go. I have eaten a macrobiotic meal of vegetables and rice with tea. Also rice cakes soaked in soy sauce and baked. To my delight this was a memorable experience. The experience had a lot of spiral effects within the mind. This was such a pronounced effect that I drew several pictures of the experience. After looking at the drawings I recognized a technical drawing I had in my own information files on physical science discoveries. It was my conclusion that two sources of information i.e. the article by Zhabotinsky-Zaikin and my own drawings were similar (Winfred 1972).

The larger mind field is shown with multiple accumulations of thought and how they

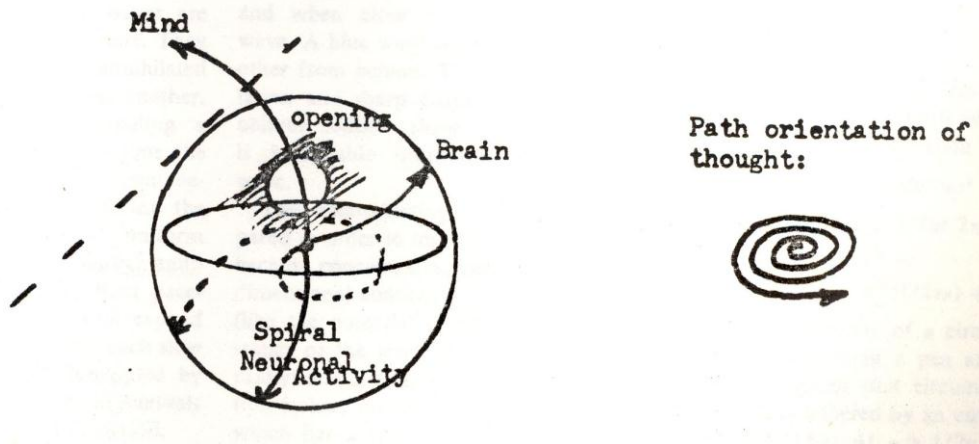

create a new frame of reference. If you try to contain the development several conditions can result.

1. Disorientation
2. Headaches
3. Uneasiness
4. Nausea
5. Chills
6. Vomiting

During this 30mg booster my headache or slight mental discomfort went away. I was able to ascend back into the progressive thought waves.

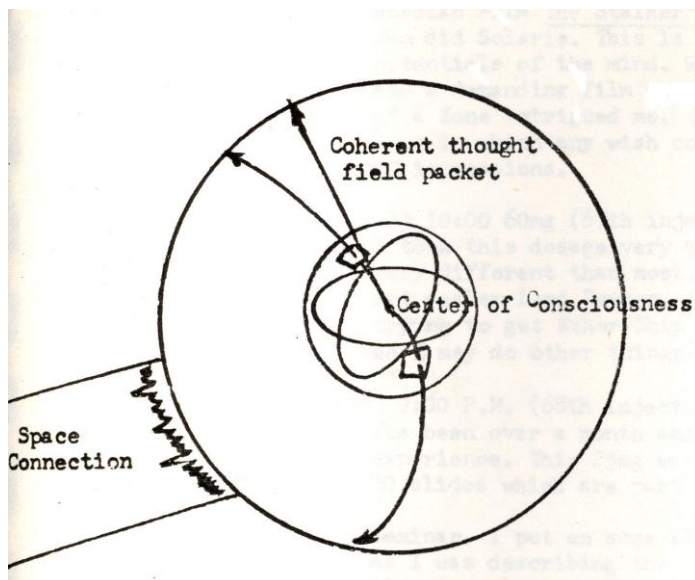

This diagram shows how I felt thought enters a larger mind field through a window in the normal frame of references we have accumulated. Sometimes the thought moves very fast in a straight line into other frames of reference which are totally new. This is a good way to chart mental landscapes. There is a boundary which I refer to as the space connection. There seems to be a realm of vibrations that can be felt once thought journeys into this close proximity to these higher frequencies. All sensations seem to fuse in this realm.

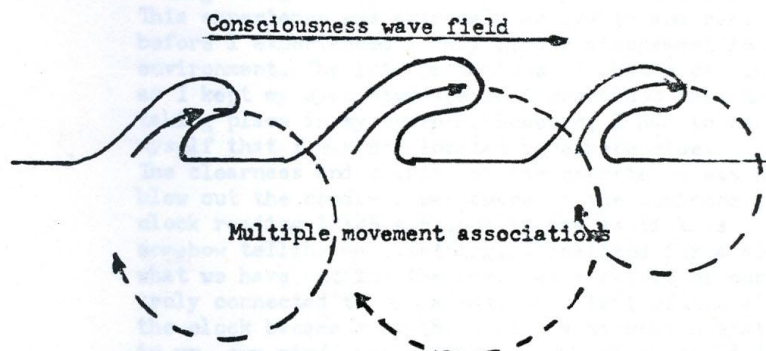

This diagram shows how there can be many thoughts occurring at once. They seemed to be rising in one direction and at the same time moving in another direction.

March 1983 11:00p.m. 20mg (67th injection) S.F. CA

I have just returned from seeing the most amazing Russian film "The Stalker".



It is by the same director who did Solaris. This is a film about the mind and the potentials of the mind. What the mind thinks about. It was a demanding film so I took 20mg to relax. The idea of a Zone intrigued me. The characters were seeking the Zone in which any wish could come true. It left a lot of impressions.

March 1983 11:00p.m. 20mg (67th injection) S.F. CA

I have just returned from seeing the most amazing Russian film "The Stalker". It is by the same director who did Solaris. This is a film about the mind and the potentials of the mind. What the mind thinks about. It was a demanding film so I took 20mg to relax. The idea of a Zone intrigued me. The characters were seeking the Zone in which any wish could come true. It left a lot of impressions. (Berhman, 1951)

March 18, 1983 - 10:00p.m. 60mg (68th injection) S.F. CA.

I took this dosage very quickly. My experience was very different than most. I had the recall of the famous art dealer Lord Duveen (Berhman, 1951). I suspect this was because I am trying to get Ether Ship Productions financially successful so I may do other things.

May 5, 1983 9:00p.m. 25mg (69th injection) S.F. CA

It's been over a month since the last Ketamine experience. This 25mg was taken just prior to showing 80 slides which are part of a seminar series on Mind Parlors. I put on some Ether Ship music and felt the K as I was describing the slides. It was as if I was in a time tunnel since the slides were of events and experiences which are apart of my life since 1968. I felt very enthusiastic and excited over my awareness with the presentation. I think this sort of activity is very useful in integrating your life.

May 5, 1983 11:50p.m. 80mg (70th injection) S.F. CA.

This evening I would like to finally experience the realms of Ketamine. I lit a small candle, took a very small amount of sensimilian and was very relaxed. I had a large dinner and presented one of my first lectures. I have also been taking 800mg of Piracetam (2-oxopyrrolidine acetamide) daily. This experience was extremely enjoyable and realistic. As before, I experienced a very strong attunement to the entire environment. The interpretations of what I was looking at as I kept my eyes open seemed incredulous that they were taking place in my bedroom. However, I had to really remind myself that I was not located somewhere else.

The clearness and clarity of the experience was new. When I blew out the candle I was aware of the luminous dial on the clock reading 12:25a.m., but it was as if this dial was somehow telling me something. I realized for a moment how what we have out in the world as a result of our minds is truly connected to our minds. The light of the dial face on the clock became a porthole into a dimension that was actually in my own mind, but seeing how the clock could do this enabled me to see the clock as the other dimension unto itself.

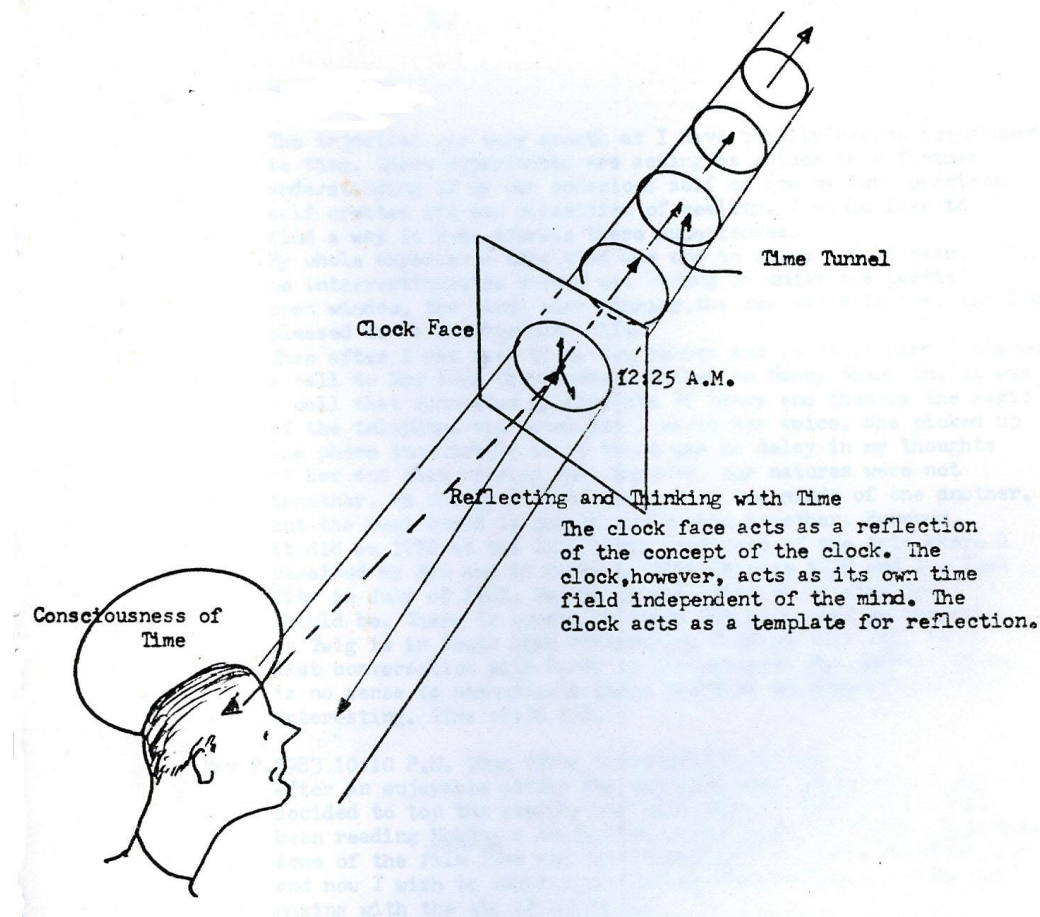

May 6, 1983 10:00p.m. - 80mg (71st injection) S.F. CA.

This was an evening in which I was extremely tired so my experience was not the same as the night before confirming previous experiences when I was tired. It seems though that a re-current theme occurs where I sense the uniqueness of each of us as individuals and the ability we have to contribute to the whole. This awareness brings to my mind how essential it is to find a way to incorporate my own universal energies with the whole. The compliment to this reasoning is if I am not here I can not affect the whole. The thought arises for me as to where we should place consciousness in the evolution of the human race.

May 7, 1983 6:00p.m. 80mg (72nd injection) S.F. CA.

Today I bought Moksha (Liberation) a survey of the letters and writings of Aldous Huxley by Cynthia Palmer and Michael Horowitz. These experiences of Ketamine were unknown to Huxley in the 60's and in order to expand my own awareness of these experiences I shall read Moksha. At this time in the day the sun is pouring in the

window as it sets over the pacific. It is now while I am fully awake and refreshed that I want to experience K on my couch in the living room.

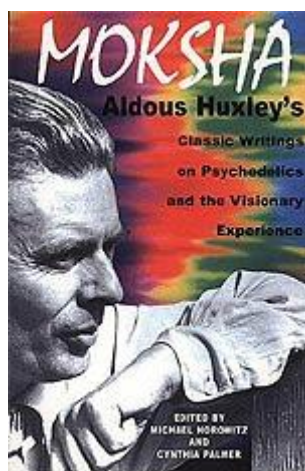

The injection was very smooth as I have totally become accustomed to them. These experiments are acting as guides to a further understanding of my own conscious self or how my own conscious self creates its own perception of reality. I would like to find a way to best express these experiences. My whole experience this time was one in which I felt calm, no interruptions, the breeze was coming in under the partially opened window, the birds were singing, the sun was shining and I was pleased to be experiencing life. Then after I was back to my own senses and state of mind I placed a call to New York City where I talked to Nancy Shamroth. It was a call that connected my thoughts of Nancy and then by the magic of the telephone via satellite I heard her voice. She picked up the phone immediately as if there was no delay in my thoughts of her and then I could hear her speak. However, our natures were not together. We occupy a place in each of our minds of one another, but the real world is not of our coming together. However, it did come together in 1970 at the California Institute of the Arts where I received my MFA and in Paris in 1974, Chicago in 1978 and New York City in July of 1981. But it is not quite as my mind feels it should be. There is something there, but it is not as tangible as Victoria Smith (Twig) from South Side Pittsburgh. I think this will be my last conversation with Nancy as she prepares for Tahiti. There is no sense to communicate where there is no connection. Very interesting. Time 7:30p.m.

May 7, 1983 - 10:10p.m.. 90mg (73rd injection) S.F. CA.

After an enjoyable dinner and watching some television I have decided to top the evening off with 90mg of Ketamine. I have been reading Moksha; a collection of writings of Huxley. I watched some of the film Time and Time Again on T.V. It was a 1979 film and now I wish to experience another time dimension of ray own making with the aid of Ketamine.

A curious thing happened this time. When I was a small boy living on 641 Broadway on the top floor in Everett, Mass and attending the Horace Mann Public school and the Highland School I was listening to the radio in the year 1946 or 1947. At that time my mother told me to go to the store and buy some bread and milk, I turned the radio off and did the errand. When I returned I turned the radio back on and was

disappointed to find my program not continuing where I had left it. At the time I could not understand that since I felt no one was around to disturb the radio. This time with Ketamine in 1983 I took this 90mg and was experiencing my room with the reflections of the candle light and thinking about the film I was watching before I took the Ketamine. When I got to the point that I wanted to see the film I was again disappointed to see only the credits at the end of the film. However, the film was very much a part of my world even while I was not watching it. I felt as if continuity in my life had been severed. I missed the characters immensely. Somehow I was in the world the film was creating, and I felt a part of that world when I was on the Ketamine. When I learned of this I turned the T.V. off in disappointment and returned to my own mental imaginings. I went to sleep and re-awoke about 2:30a.m. Then I retired.

May 8, 1983 - 2:15p.m. 60mg (74th injection) S.F. CA.

I am sitting outside amongst the redwood trees in Golden Gate Park. This will be the first time I have administered Ketamine in an outdoor setting. I want to experience the integrated effects while hearing all of nature. The entry was very smooth, the sun is warm, and there is a strong breeze with no clouds. I can smell the grass, hear the birds, and now I wish to just experience. I was going to walk to the ocean but I felt it was too far, and I really wanted to feel this Ketamine experience as soon as possible on the nice day. The sun was making shadows from the blades of grass on my writing paper so I took a pen and traced these shadows. The drawings are made here as an example but are not the originals. Being with the grass was an all encompassing effect. These are shadow drawings of grass on my paper. I am really in the soup of life. Thinking of Cape Cod. Thinking where a place where words roam the whole day long. Mankind does, but mankind as a whole does not question. There is also the continuity factor. If all of my acts have not created an effective insertion into society then I will try to come up with another one. Why?

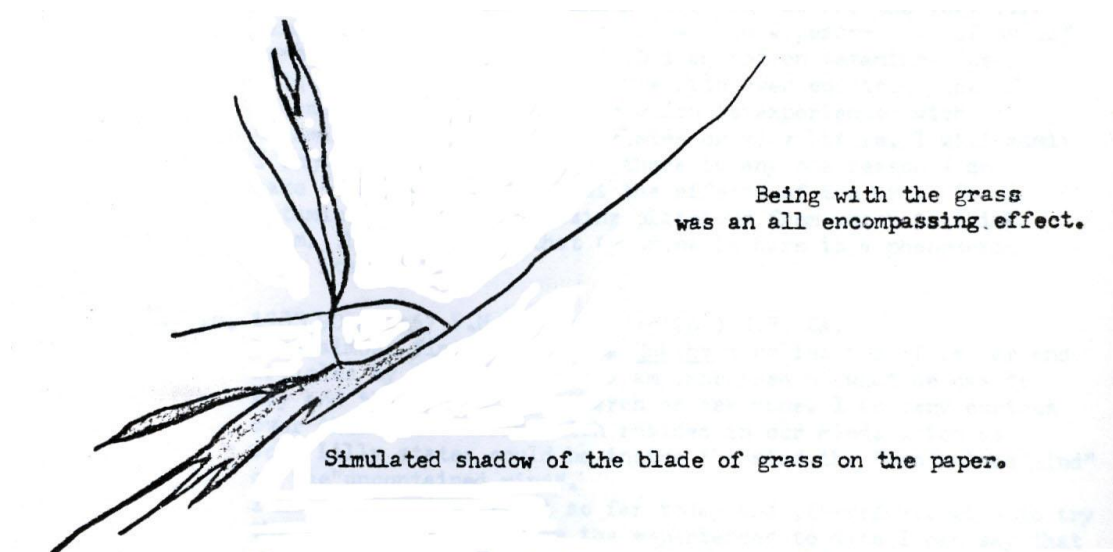

May 8, 1983 - 4:10p.m. - 30mg (75th injection) S. F. CA.

Just before I went to the beach I took some Ketamine and now the sea is perpetually pounding on the sand. Clear blue sky, very strong wind, and its very warm. A ship heads out to sea, a dog runs by, gulls flying to and fro, smells of a salt breeze; it is good to experience this world this way. It's as if I had a shroud of warmth around me. But it is a rough sea, not manageable; these words by the sea can not even begin to portray all the events going on simultaneously. There is so much sea here that to reveal it by my pen is not possible. I remember the Sunday newspaper of the people in Mexico, or the woman Hoey who fell on Mt. Everest ••• , yes it's our life isn't it? All of us here and on this Mothers Day.

Note: *Marty Hoey* (1951 – May 15, 1982) was a mountain climber who took part in the 1982 expedition to Mount Everest. During an attempted ascent that would have made her the first American woman to summit Everest, she plunged over the edge of the Great Couloir and died. The cause of her death was an unsecured climbing harness. Hoey worked for Dick Bass, at his Snowbird ski resort. She befriended him and accompanied him on his successful ascent of Mount McKinley and he was also a member of her climbing group when she perished on Mount Everest in 1982. When Bass eventually summited Mount Everest in 1985, he dedicated his ascent to her.



This Mothers Day the telecommunications people are going to present "Apocalypse Now". I don't think that's very appropriate do you? And of course who is you? Then a walk into the wind along the beach and then to the Cliff House for an Irish coffee. Today was a day for nature. With a morning jog, to reading Moksha in the Shakespearian Garden in Golden Gate park until noon, to the Ketamine in the redwoods and then a walk to the beach

May 8, 1983 - 90mg 11:15p.m. (76th injection) S.F. CA.

At this time I want to feel the accumulated effects of the day. I have just finished watching *Apocalypse Now* for the very first time. This experience provided me with a perspective of myself sensing more than I sense when I am not on Ketamine. The unique development which occurs with continued use of Ketamine is that the reality which is experienced with Ketamine has no verbal correlates or very few. I will admit I enjoy this experience. If there is any one reason that I do take Ketamine it is to feel

the effects of the drug. To me Ketamine provides a pleasing platform from which to think from. The fact alone that Ketamine is here is a phenomenon unto itself.

May 14, 1983 - 90mg 2:57 p.m. (77th injection) S.F. CA.

I am almost finished reading, Moksha, a collection of letters and articles by Aldous Huxley. I am impressed by what he has to say and the amount of research he has done. I am very curious over this other world which resides in our minds which as John Lilly states, could be inside the mind the "contained mind" or the "uncontained mind". I have eaten very light so far today and, therefore, wish to try the Ketamine again. From the experiences to date I can say that it is unexpected what will occur. The transfer of the Ketamine state into the consensus reality is the area of my research at the present time. I have also prepared a 30mg dosage as a booster to see what effects take place by adding to the original dosage when it begins to wear off. The entry was extremely smooth with no needle sensation what so ever. Food intake today was coffee, a breakfast roll, and #1 egg, two slices of bread and 800mg of Piracetam. I can now feel the Ketamine and it is a familiar and welcome sensation. This time I did feel the forward motion into the "time field" (McKenna) as well as the on rush of light (Huxley). We appear, as humans, to be creating forward on a spiralic path. That seems consistent with other findings so the best approach is to use the mental resources where they can be utilized for further research and development of consciousness as a distinct phenomenon.

May 14, 1983 7:15p.m. 30mg (78th injection) S.F. Ca. plus a Friend 30mg

This evening I decided to do 30mg socially with my good friend Arman. There was reluctance seeing as the former research with a recreational approach did not reach the thought exploration level as I wished it too. However, a lot was experienced with Roy Brown and the great amounts of continued use of Ketamine revealed a unique setting as a result of maintaining a wakeful state with eyes open. (Refer to Dec 82 documentation)

Arman, on the other hand is an accomplished writer and has written a provocative paper on thought engineering. This paper can be found in my booklet "Mind Tribes". When we first took the Ketamine together it was difficult to talk, but we did uncover a thinking language that went along with the Ketamine experience. It was agreed that the mental state on Ketamine does not allow the fixed arrangement of words as we know them to be associated for speaking, but it would be necessary to have words that display motion. This sounds like the "Rohe Mode" that Dr. David Bohm is talking about in his book Wholeness and the Implicate Order.

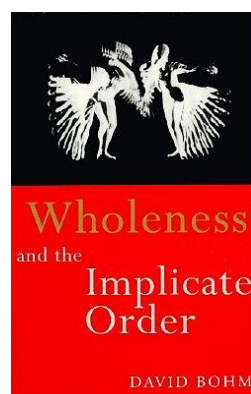

May 14, 1983 - 9:30 p.m. 60mg (79th injection) S.F. CA. plus Friend 50mg.

Now after a dinner of rice and vegetable and coffee both Arman and I will increase our dosages. Arman seems quite receptive to the experience probably because he smokes so much Sensimian. It was at this time that I suggested that we watch television because I remembered that experience before with Roy and wanted to see the comparison with Arman. Synchronicity played the hand well because Peter Ustinov was narrating on the history of revolution in Europe.

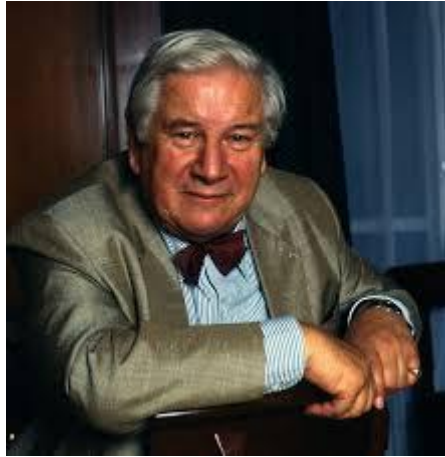

Peter Ustinov

This was a series on KQED. This worked well because Arman has revolutionary ideas and he could relate to the program. The title of the program was "Certain amount of Violence". Prior to watching this program I got a telephone from a friend who has collected an extensive amount of research on Ketamine and who is in the area. We made arrangements to meet the next evening. My immediate impression on the program and the way it was put together was the last scene where the rioting students in Paris were raising their fists in protest. The close up of the waving pounding fist looked as if it were banging on the other side of the television screen. As a collected species on this planet there is a lot of fist waving to prevent a nuclear war. This program set up the continuation of the evening to discuss societal problems in the world. We both went to the kitchen and made some more coffee and went to the living room where we both did 30mg each.

May 14, 1983 11:05 p.m. 30mg (80th injection) S.F. CA, Friend 30mg

For me this was a total of 120mg since 1:15 p.m. and for Arman it was 110mg. I was very surprised to experience a remarkable increase in the sensed effects of Ketamine. It was extremely intense yet we were both awake and alert. It was also possible to talk. The mental state was very introspective. At this time we were discussing the differences in belief structures. One such example was the comparison of military tactics and how one system carries over to the next century without a change in the mental set.

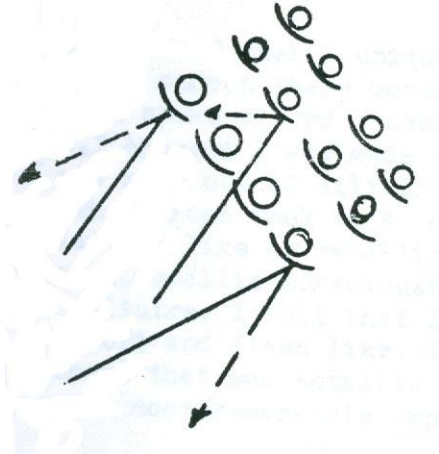

This diagram shows a 12 century infantry formation with shields warding of lances. The mental shield deflects the missiles.

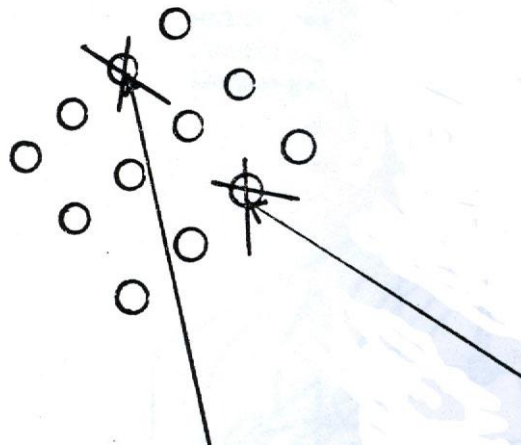

The carry over of the military formation into the 17th and 18th century for Britain shows how musket balls can easily penetrate the formation and kill an infantry member. The Roman grid system was out dated for modern warfare. In the present day and age many older ideologies that were applicable for their time are not useful in the 21st Century. The defense of nation states has to be looked at anew.

The television uses the older medium of film and utilizes the newer technology to display its images. This idea was brought forth by the Canadian communications and English professor Marshall McLuhan in his book *The Medium is the Message*. These diagrams were brought about by looking at the world with a new sense of openness triggered by Ketamine. The strict hold of certain thought constructs could be seen for their usefulness at one time, but also their obsolescence at another time.

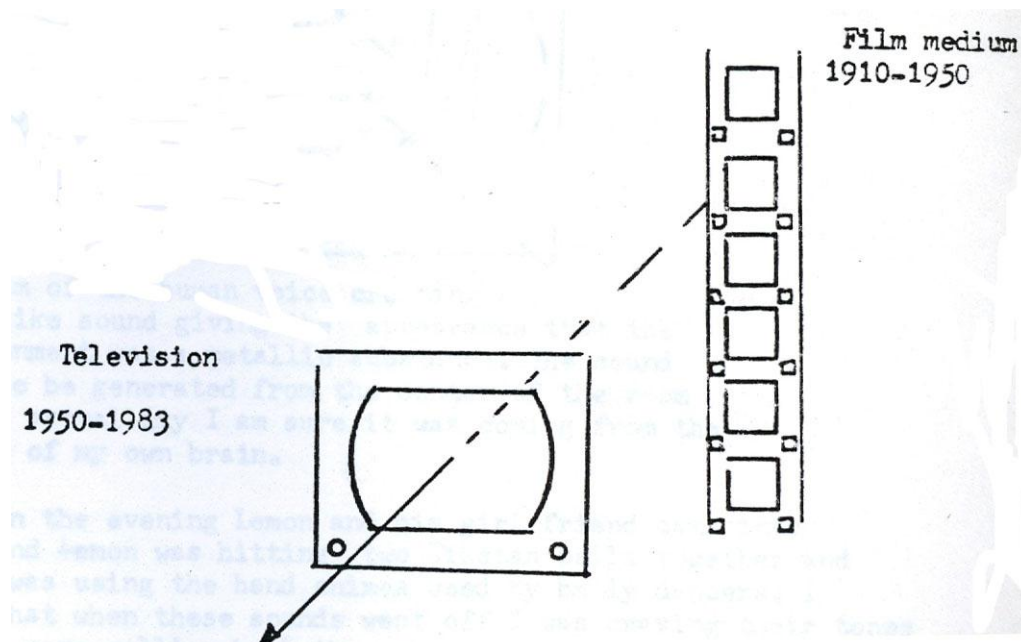
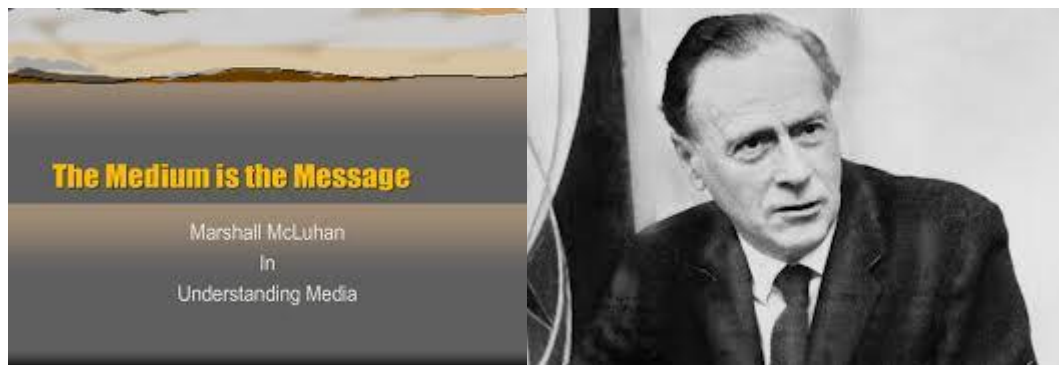

Diagram showing how a new medium displays the older medium



Marshall McLuhan and his ground breaking book

Our discussions lasted a long time, and then a unique sensed mental phenomenon occurred. All of a sudden there occurred in my head a ringing sensation. When I spoke a word, I could hear a resonant ringing in my mind. I thought I was made out of a metallic substance. I thought I was made out of silicon or some other Metallic substance. The whole room took on a quality of exactness as if it were all very lattice like or metallic like. I could definitely feel there was a metallic consciousness allowing metals to appear in our culture. I felt that I was metallic even though I knew I was soft and flesh like. I sensed that in my mind there was an element that was metallic in its ability to govern my body. It was a most remarkable experience and one I can not forget.

The discussions lasted longer, and then a unique sensed mental phenomenon occurred. All of a sudden there occurred in my head a ringing sensation. When I spoke a word, I could hear a resonant ringing in my mind. I thought I was made out of a metallic substance. I thought I was made out of silicon or some other Metallic substance. The whole room took on a quality of exactness as if it were all very lattice like or metallic like. I could definitely feel there was a metallic consciousness allowing metals to appear in our culture. I felt that I was metallic even though I knew

I was soft and flesh like. I sensed that in my mind there was an element that was metallic in its ability to govern my body. It was a most remarkable experience and one I can not forget. There is an attunement with all of your systems in this state. Each aspect of consciousness enfolds upon itself to create a tone which seems to be in the center of the environment which I was functioning in. This was a phenomenal experience. Again, there is language parameter to incorporate.

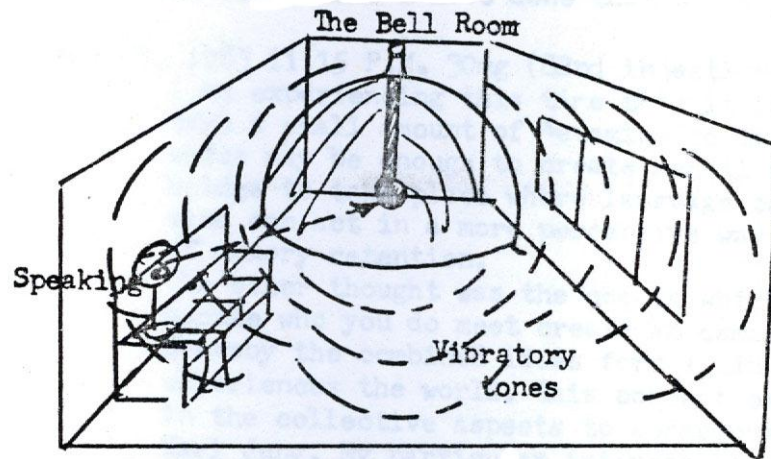

Diagram of the human voice creating a bell like sound giving the appearance that the environment was a metallic substance. The sound seemed to be generated from the center of the room but in actuality I am sure it was coming from the center of my own brain.

Later in the evening Lemon and his girl friend came into the room and Lemon was hitting two Tibetan bells together and Christine was using the hand chimes used by belly dancers. I detected that when these sounds went off I was craving their tones as if they were calling back the experience I had with Ketamine in the Bell Room phenomenon. I can recall many times when I was playing the electronic synthesizer in concert that the higher frequencies would be played but I would not hear them. It is as if some frequencies act as a carrier wave for other frequencies. Thought may in fact be carried by subtle frequencies we do not even hear such as magnetic waves and other inter stellar frequencies. Humans may be communicating with other entities that only evolution will allow knowledge of to occur.

May 16, 1983 11 :20 p.m. 50mg (81st injection) S.F. CA

This evening is just to re-experience the Ketamine after seeing Dr Frank Barr, and his extensive work with Ketamine and his information on how Ketamine bonds with melanin which resides in the center of the cell. Dr. Barr is also familiar with the concept of a silicon culture and his research with Ketamine is crucial to analyzing the future of consciousness. I will be able to do more research with his colleagues. This experience was not realizable since I was so tired that it had no memorable effects. Included here is a paper on how ketamine interacts with the brain;

What is Melanin?

By
Frank E. Barr M.D. 1983

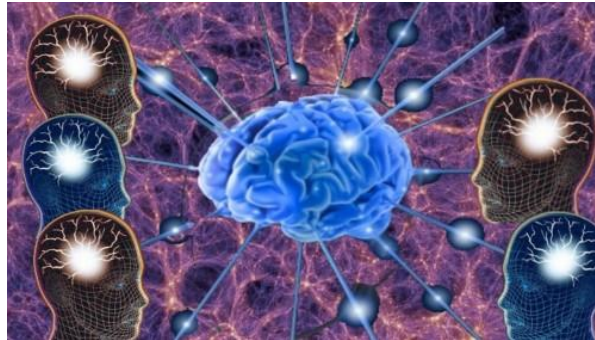

Melanin: The Organizing Molecule

Dr. Frank Barr, pioneering discoverer of melanin's organizing ability and other properties, theorizes in his technical work,

This paper presents a cursory review of only a few of the potential organizational properties of melanin. An in-depth discussion of these issues is presented in two papers: "Melanin: The Organizing Molecule" (Medical Hypothesis 11 (1): 1-140, 1983) and "Melanin and the Mind- Brain Problem" (unpublished). Please address inquiries regarding these articles to Frank Barr, M.D., Institute for the Study of Consciousness, 2924 Benvenue Ave., Berkeley, CA 94705.

Related paper: The Theory of Process: <http://www.arthuryoung.com/barr.html>

"Melanin" is an ancient, very complex, black molecule (or more precisely, a category of related molecules) with unique light- and sound-absorbing and photon-(exciton)-phonon interconversion properties (a phonon is a unit of vibrational energy, a quantum of an acoustic mode of thermal vibration.) Melanin's remarkable stability and stubborn resistance to the usual methods of chemical analysis have led to such labels as "chemical fossil" and "black box." It is an extensively distributed biopolymer and has been abundantly found in 150 million year old dinosaurs as well as human mummies. A noteworthy fact is that the circulation of melanin in primitive organisms is phylogenetically much older than the circulation of blood.

M.S. Blois, a Stanford biophysicist, previously recognized the organizing potential of melanin and suggested that it was the "first polymer", preceding and possibly directing the formation of proteins and nucleic acids. John Oro, current editor of the Journal of Molecular Evolution, has proposed that the closely related pre-biotic polymer, melanoidin, because of its special properties and "directing ability", may have acted as an organizing matrix for the specific selection of the ribose sugars and nitrogenous bases which constitute the nucleic acids DNA and RNA.

Among the exceptional features of melanin are:

- 1) the ability to scavenge, produce, release, and manipulate "free radicals" (highly reactive unpaired electrons) and to maintain a stable free radical signal, as detected by electron spin resonance;
- 2) the capacity to bind and release the full range of metal ions, which are involved in such crucial functions as the activation of enzymes, the organization of membranes, the performance of cellular organelles, etc.;
- 3) the ability to function as a semiconductor with physiological responses to photic, acoustic, and electrical stimulation, its conductivity significantly changing with its reversible and irreversible binding ("doping") of various substances; and
- 4) the ability to strongly bind numerous major functional molecules, ranging from the various psychoactive drugs to the toxic herbicides and pesticides.

Through its dramatic ability to manipulate free radicals, peri-nuclear melanin has the potential to continuously control the synthesis of DNA. For example, the DNA synthesizing enzyme, ribonucleotide reductase, is probably activated by its recently discovered stable tyrosine free radical, an ideal locus for melanin regulation. Likewise, guanylate cyclase, the enzyme which makes the highly functional "second messenger", cyclic GMP, is activated by free radicals, accessible to regulation by melanin. The breakdown of membrane components such as arachidonic acid leads to significant free radical production. Most, and possibly all, major metabolic and pathological processes involve free radicals. Even the life-sustaining molecule, oxygen, functions via highly reactive free radical mechanisms associated with melanin.

Most enzymes require metal ions in order to perform their catalytic functions. In order to function, the various enzymes which synthesize and maintain DNA and RNA, for example require metal ions, particularly zinc ions, which are highly concentrated in melanin. Melanin, as a cation exchange polymer, most likely supplies these crucial ions as needed and consequently can theoretically control nucleic acids, proteins, phospholipids, and other important molecules, as well as cellular organelles, such as the cytoskeleton. In fact, melanin appears to be closely linked functionally and anatomically to the cytoskeletal microtubules and micro-filaments which compose the cellular "freeway system" that rapidly transports molecules and organelles throughout the cell. The centrosome (and its centrioles) in the center of the cell is the "hub", and organizing center of the microtubules. The study of such intensely melanized cells as the chromatophores has shown that melanin can be instantaneously transported from the centrosome to the outermost periphery, the plasma membrane, and vice-versa. Melanin possesses numerous available mechanisms which potentially allow it to control the centrosome and the microtubules and microfilaments of the cytoskeleton. Many of the same acidic proteins which compose the cytoskeleton (e.g. actin, myosin, tubulin) have been suggested to turn the various genes within the nucleus on and off. In fact, the cytoskeleton appears to actually penetrate the nuclear membrane and to be closely associated with the chromosomes within the nucleus. Furthermore, the cytoskeleton is significantly involved in controlling the mobility of the plasma membrane and the antennae-like "receptors" protruding from the outer surface of the plasma membrane.

These receptors respond to neurotransmitters, peptide hormones, antibodies, electromagnetic radiation, etc. and are continuously transported (via the cytoskeleton) from the cell surface to the lysosomes within the cell, and back again to the cell

surface. This is potentially very significant because the highly organizational lysosomes contain a significant amount of melanin (usually within the larger storage molecule, lipofuscin) as well as a large number of organizational enzymes. Lysosomal melanin could thus easily "process" the cell surface receptors (and their ligands) and concomitantly activate specific genes, through control of the cytoskeleton. This melanin-directed processing could therefore coordinate the "genetic potential" of the nucleus and the "environmental activation" of the cell surface receptors (during embryological development, for example).

Some other important related organizational mechanisms for melanin are the following: (discussed in the two melanin articles--see previous footnote)

- 1) its photon-(excited electron)-phonon interconversions;
- 2) its scattered regions of high paracrystalline order and its potential superconduction at room temperature;
- 3) its potential regulation of covalent modifications (e.g. peptide cleavage, phosphorylation, methylation, tyrosylation, adenylation, acetylation, uridylation;
- 4) its potential organizational genesis and control of:
 - a) tissue differentiation (embryological development),
 - b) tissue repair/regeneration, c) the immunoregulatory system, d) the autonomic nervous system, e) the neuroendocrine system (i.e. the amine neurotransmitters and the peptide hormones), and especially f) the higher mental functions.

Tissue differentiation (and regeneration) is apparently guided by an organizing flow of sustained current generated at the cellular level, and first detected at the pigmented (melanin-concentrated) pole of the oocyte. This sustained current is modulated by various mechanisms, accessible to control by melanin, that regulate ion flow and the electrotonic gap junctions connecting the embryonic cells. In vertebrates, melanin is significantly related to the neural

crest, the embryological system that brings together the folds that make the neural tube, which then matures into the central nervous system--the brain and spinal cord. The neural crest system disperses throughout the body, forming the diffuse neuroendocrine system. The neural crest has recently received a tremendous amount of attention as the embryological "organizing system." As it is responsible for the formation and intricate coordination of the face (dermis, muscles, bones, vessels, glands, etc.) as well as the peripheral nervous system, endocrine organs, major blood vessels, etc., many researchers are convinced that selective malfunctioning of the neural crest (through means such as drug binding and damage during pregnancy etc.) is a major cause of most congenital defects. Melanin is concentrated in the eyes and ears where it is involved in light (photon) and sound (phonon) absorption. Many forms of blindness and deafness are related to melanin abnormalities.

The continuum of melanin from the autonomic and sensory ganglia to the top of the brain-stem is called the "brainstem melanin system," and this particular type of melanin is called neuromelanin. Albinos--which have decreased or absent tyrosinase-derived melanin, probably the least important though clearly the most grossly observable type of melanin because of its role in producing one's skin colorless appear to have normal concentrations of the other types of melanin, including neuromelanin. The various melanins are very complex biopolymers formed by numerous mechanisms, most of which still remain obscure. The most interesting varieties of melanin are very closely related to neuromelanin, are associated with a complex arrangement of lipids (and proteins), and are usually called lipofuscins. Lipofuscins,

though first detected in the fetus, accumulate throughout one's life and have therefore been called "aging pigment." When dissolved in plasma and transported in a soluble form in the blood, these lipofuscins have been called "melanins." (Melanin may also be synthesized and transported by white blood cells and mast cells, especially to areas of tissue damage where it is most likely involved in directing tissue repair and/or regeneration.) The past assumption that lipofuscins were merely harmful waste products reminds one of the previous simplistic view that the lysosome's function was to "lyse" (or kill) the cell. Such limited assumptions, of course, remain unproven even after years of intensive research, and consequently many researchers are now proposing that the widely dispersed lipofuscins serve one or more essential metabolic roles.

Polymers are made up of smaller units called monomers (e.g. nucleic acids are composed of nucleotides and proteins are composed of amino acids). However, it seems especially fascinating that the neuromelanin of the brainstem is primarily composed of such highly functional "monomers" as the widely dispersed monoamine neurotransmitters (dopamine, norepinephrine, and probably serotonin). Furthermore, neuromelanin increases with phylogenetic ascent, reaching a peak in man. The Medical Hypothesis article discusses research which suggests that neuromelanin is an autopoietic (self-organizing) polymer, whose functions are due to its quality of interval arrangements and its complexity of interrelations and not to its gross quantity. The brainstem melanin system is the site of origin of the extensively distributed monoaminergic nerve fibers which primarily release their respective neurotransmitters from axonal varicosities, rather than classical synapses. Recent evidence strongly suggests that the most important site of action of these neuromelanin-regulated monomers may be the neuroglial syncytium. The neuroglia constitute 90-95% of the brain cells, and appear to direct the growth, connections, and physiological functions of the neurons. They are connected with each other through gap junctions, which can be selectively opened or closed simply by changing the intracellular pH, a mechanism readily available to neuroglia.

The neuroglia appear to maintain a sustained current that is continuously modulated (either locally or diffusely) by monoamine neurotransmitters, which, in turn, are most likely phase-regulated by the brainstem neuromelanin-system. Using computer terminology, Robert Becker has noted that the direct current of the neuroglia can be considered to be "analog" in nature while the all-or-nothing (on-off) action potentials of the neurons can be thought of as "digital". Neuromelanin-controlled localized "biasing" of the neuroglial analog current could easily control the local synaptic graded potentials of neuronal dendrites, which are conveniently surrounded by neuroglia, and this biasing could thus result in strategic neuronal (digital) firing. "Planes" of lipofuscin are found throughout the cerebral cortex and could indeed function as a sort of "holographic film," capturing wave interference patterns and storing memories. In fact, the continuous accumulation of lipofuscin may directly correlate with the continuous accumulation (storage) of memory. Of particular interest is the accumulation of serotonin-related lipofuscin within subicular dendrites of the memory-associated hippocampus. This highly researched region of the brain's limbic system has been shown to ratiocinate or compare (by its meticulous brainstem-regulated phase-timing) the sensori-motor "here and now" with memories, anticipations, and plans.

The part of the brainstem neuromelanin system called the reticular formation/reticular activating system has long been known to generate conscious awareness in general. The raphe-serotonergic part of the brainstem neuromelanin system has been proposed by Arnold Mandell to control altered or "transcendent" states of consciousness, such as those states induced by various psychedelic drugs or advanced meditation. The neuromelanin-laden substantia nigra/ventral tegmentum-dopaminergic system and the locus coeruleus-noradrenergic system also are crucial for generating attention, experience, memory, cognition, and sensori-motor behavior. In addition to producing consciousness and altered states of consciousness the brainstem neuromelanin system is necessary for:

- 1) the control of vital autonomic functions (including respiratory and cardiovascular control);
- 2) the organization of electroencephalographic activity;
- 3) sensori-motor and emotional-motivational integration;
- 4) the regulation of sleeping, dreaming, and memory; and
- 5) the regulation of physiological rhythms and immune-regulation.

Peptides appear to be intimately involved in experiential memory, emotion, motivation, and trophic responses (inner or subjective experience), while amines are involved in sensory input, data transmission, and motor output (outer or objective experience). Neuromelanin—through;

- 1) its photon-phonon-(exciton) -(soliton) interactions;
- 2) its semi- (and possibly super-) conductive capacities;
- 3) its cation exchange flow;
- 4) its continuous free radical signal;
- 5) its neuroglial direct current;
- 6) its potentially diverse covalent modifications;
- 7) its potential to trigger reversible enzyme cascade amplifications; etc.--could precisely regulate the neuroendocrine system. By meticulous phase-timing, neuromelanin could coordinate the synthesis, release, uptake, destruction, modification, and/or recycling of the various monoamines and peptides throughout the brain. In short, this remarkable, previously neglected, molecule could be responsible for our experience of a continuum of mental states. Furthermore, even very slight (potentially undetectable) alterations of the brainstem neuromelanin-neuroglia system and its precise phase-timing regulation of the monoamines and peptides could result in such mental disorders as schizophrenia and manic-depression. It is important to note that neuroleptics (anti-schizophrenia drugs) bind to both neuromelanin and its neuroglial receptors, apparently stabilizing, at least transiently, the aberrant neuroendocrine phase-timing in these disorders. Neuromelanin would thus appear to be a candidate for sophisticated high priority research.

Such researchers as Ross Adey, Karl Pribram, Arnold Mandell, Bevan Reid, John McGinness, Peter Proctor, Stuart Hameroff, Michel Bornens, Amit Goswami, Ralph Abraham, Francisco Varela, and Terence and Dennis McKenna have recently suggested several exciting mechanisms (compatible with the properties and functions of melanin) that deal with form dynamics, self-organization, and the effective regulation by very weak electromagnetic interactions of molecules, organelles, cells, and neuronal assemblies. Electronic (graded potential) processing in neuronal systems may be maintained near threshold and effectively triggered by as little as one photon or auditory (phononic) input near that of mere Brownian motion. [Melanin is one of

the best known sound/vibration absorbers and is a "black box" for electromagnetic radiation including and beyond the visible spectrum.] Cooperative/non-linear mechanisms and "soliton" models offer exciting new explanations for well-documented electromagnetic frequency and intensity "windows" which can produce physiological responses at gradients several orders or magnitude less than those classically considered necessary to generate neuronal action potentials. The above researchers and their theories promise to significantly advance our knowledge of psychophysiological processes.

However, I believe that the person likely to contribute the most to our understanding of bio-systems is Arthur M. Young. This philosopher, scientist, and inventor of the Bell helicopter has re-discovered and developed what he calls the theory of evolutionary process, a comprehensive paradigm with a remarkable potential for integrating current facts and theories and for accurately predicting new facts and theories. It was his theory, in fact, that stressed the ontological significance of the photonic "quantum of action" and predicted my own findings regarding the photon-capturing melanin molecule. In further applying his theory to neurochemistry, neuroembryology, and functional brain-mind systems (neuropsychology), I have personally verified its integrative accuracy--a wide-ranging rigor which appears to be unparalleled in the history of philosophy, psychology, biology, and neuroscience. (These preliminary findings and a proposed solution to the "mind-brain" problem are outlined in "Melanin and the Mind-Brain Problem.") Young's toroidal process theory encompasses both ancient wisdom and the gamut of contemporary science and is therefore too extensive to be outlined here. However, I wish to strongly encourage other cross-disciplinary researchers to seriously consider Young's paradigm and subsequently to apply it to all current major unsolved mysteries.

May 17, 1983 11:20 p.m. 30mg (82nd injection) S. F. CA

I am having coffee with brandy and I am thinking of the amount of work I have placed before me so that I can participate as well as learn. Huxley's writings are indeed significant and I could not agree more that looking into the phenomenon of consciousness is very human ••• is very significant. I took some pictures of flowers today as well as trees. This is the first time I have done that since 1962.

May 18, 1983 11:15 p.m. (83rd injection) S.F. CA

I am experiencing this time that it is only necessary to take a small amount of Ketamine to trigger the sensation which may be enough to create mental pictures allowing a bridge to take place where language could act, or the conscious mind can act in a more perceptive way with a greater amount of memory retention. The other thought was the one in which I could sense that people who you do meet create an osmotic learning syndrome whereby the combined ideas from a link in how one personally experiences the world. This concept extended would result in the

collective aspects to consciousness referred to by Karl Jung. My particular interest is with the philosophy of Dr. Oliver L. Reiser and his work with *Cosmic Humanism* and his concept of the "Psychosphere". The full text is now downloadable at:
<http://www.tandfonline.com/doi/abs/10.1080/02604027.1971.9971760#.UyJNUs7WiCU>

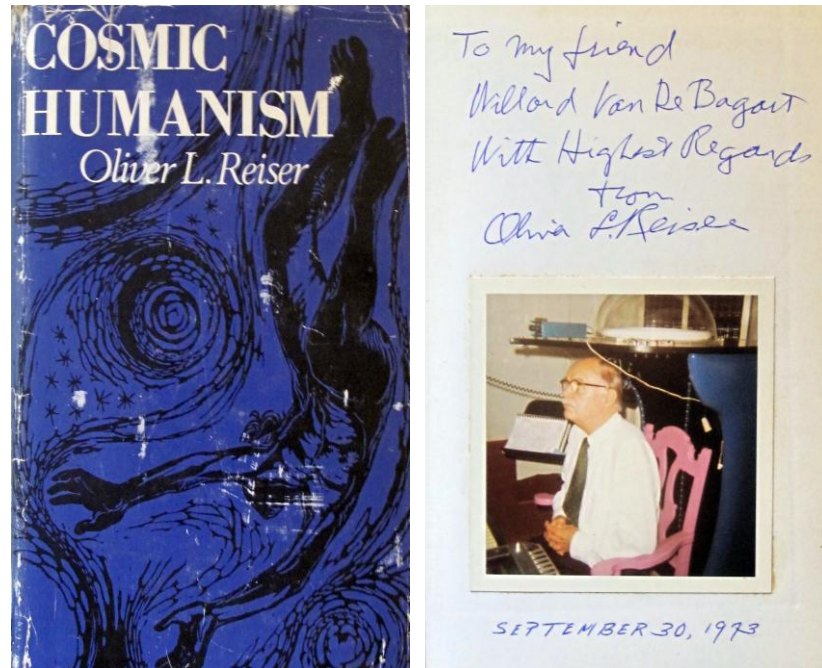

Oliver L. Reiser sitting in the Ether Ship

This experience was prefaced by a few tokes of sensemillian which I think helps the small amount of Ketamine since it does have a high amount of THC. This particular dosage enabled me to pay attention to my thoughts.

May 19. 1983 10:30 p.m. 30mg (84th injection) S.F. CA

This evening I am alone trying to see if I will have more thoughts as a result of taking Ketamine in conjunction with sensemilian. Indeed I did. This intensity of perception easily lasted until 11:30 p.m. and I did not retire until 12:30 a.m. I was hearing all the subtly around me, and I felt an urgency to inform people of this unique human gift of thought which is used in so many alarming ways. I tried to imagine a race of humans who were all of a sudden awe struck over the fact that consciousness was destined to become a planetary "Psychosphere". Then perhaps the entire human race would feel its affinity to life in this corner of the universe. Why the human mind looks into various ideological systems is testimony to the underdeveloped nature of mankind. It seems that human potential is best actualized when the psychic powers that enable thought to take place are taken into consideration and dealt with as a biological force that organizes life. Then I was in communication, or I saw how all the plants, the desk lamp, and myself were a part of an evolutionary process. The light became a mini sun. The light was just as much a part of the evolutionary process as I was. This awareness allowed me to see how each object was bound to the other to define reality. Then I mentally removed myself from the setting and the plants, and the light I felt

would still continue to be there. But then I thought the plant needs water, and the bulb will burn out. Therefore, there is a life matrix within an environment. I have felt this sensation with the television, and once in Paris in 1975, when I fainted in the lobby of the American Cultural Center. Somehow the heat in the theatre at the American Cultural Center on 3 rue Dragon, and the effects of taking some marijuana caused me to faint. When I came to I saw how each thing in the environment was mentally connected to define that environment.

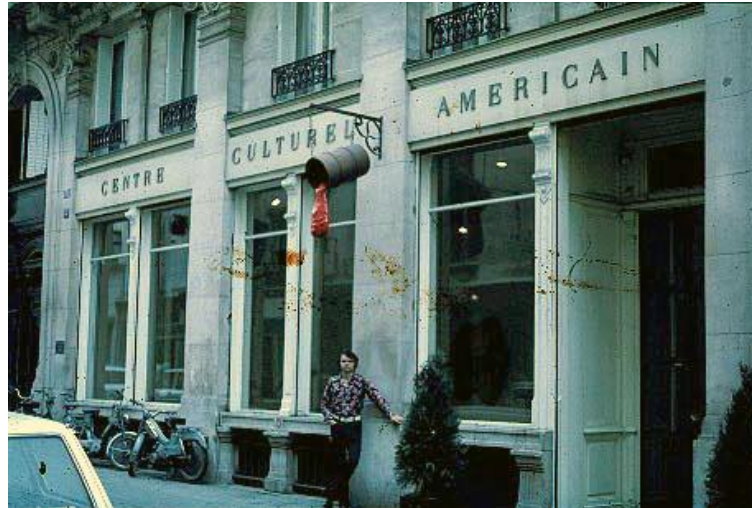

Standing in front of the American Cultural Center, Paris, FR May 1975
http://www.earthportals.com/Portal_Messenger/infinitevision.html

May 20, 1983 7:45 p.m. 30mg (85th injection) S.F. CA.

The text *Psychedelic Drugs Reconsidered* by Lester Grinspoon is an excellent overview of mind altering substances through the ages. The last two evenings have been extremely interesting as a result of combining sennellian with Ketamine. My curiosity is now triggered to understand why it is the human brain has the capacity for a very different sort of consciousness than is experienced every day in an agreed upon normal sense. This evening I decided to watch television again. I saw the "Princess of Cocaine" story and Andrew Stern's "How Much is Enough" which concerns nuclear missiles. It is obvious mankind is caught in a mad situation am so am I. The comparison of this experience with yesterdays demonstrates the minds reaction to different stimulus. Last evening was the world which I was immediately in or immersed in, and this evening I was in Bolivia and the civilizations of Germany, France, England, the Soviet Union and America. All this was experienced through television. The size of the arsenals in the world makes me feel that any direct action on my part to abolish this situation would be insignificant.

May 28, 1983 7:10 p.m. 40mg (86th injection) S.F. CA.

The recent readings in Grinspoon & Bakalar's book *Psychedelic Drugs Reconsidered* has many citations on what others have felt on taking L.S.D., Mescaline, MDA etc. My own Ketamine experiences have also been documented. As time flows through the human experiencing mechanism there are constantly new thoughts being generated. Of late my interest is in this other world aspect that is within the neural networks. This 40mg has been taken to feel and realize areas of thought that are new. The Ketamine is a "reality contributor". As the sensation occurs thoughts also appear so that I may participate with the affects.

At 7:45 p.m. I turned on the lights and knew that thoughts were important. I feel very in touch with my own world. A "think tank" comes to my mind. Rolf von Eckartberg's work combined with Dr. Reiser's work will provide the necessary platform to go forward with such a "think tank". And now I journey into a book written Dr. Albert Hofmann titled *LSD my Problem Child*.

May 28, 1983 11:55 p.m. 60mg (87th injection) S.F. CA.

I have just seen a film, "A Time for Revenge", made in Argentina. The repressive quality of this nation always is brought out to the attention of the free world. This Ketamine experience is to feel the release from the political tensions I observed. In my world it is the exploration of what the mind can do. This truly intrigues me. This experience brought to my awareness all the artifacts I have collected and how important it is to steer my accumulated history into a focused activity whereby the ideals I have set for myself can be actualized. Another thought occurred to me concerning living more than one complete life style simultaneously. Example: Living in one city complete with friends, perhaps a family, and due to business I would have a complete life style in another city or even another country. This state of affairs may come about as a result of faster transportation and instant telecommunication systems. This would follow along the lines of serial programming whereby humans would learn how to manipulate various thought patterns without alarm or confusion.

May 29, 1983 5:00pm 100mg (88th injection) S.F. CA.

Today is perfect. It's calm, the sun is centered on the picture window, there is a light breeze, it is warm, clear, and I have just enjoyed a brisk walk from Carbon Alternative on the corner of Market and Divisadero streets to 11th Ave. I stopped to have a cup of coffee at the Grand Piano on Haight Street and gained a lot of fresh air. I do not smoke cigarettes. This is an excellent time to do Ketamine. I will not be disturbed, to my knowledge, and I have wanted to do 100mg for some time. The last was on March 8, 1983. I need to transport my ideas into the Ketamine hyper-space. I need to utilize this potential "mental activator" to enable me to solve problems and make decision better. I am interested in exploring the unique biological functioning of mind in the universe or at least on this planet. It's one of nature's best kept secrets. Actual entry 8:17 p.m. There have been times 100mg would not affect me and other times it would. It is all in the timing of the day, the mood, temperature, expectations, prior experiences and many more environmental conditions. This is a turn key event to find the right combination of events to affect consciousness so as to learn from the phenomena. Time 5:20 p.m. and the Ketamine is coming. I feel the breeze, the air, and this day is like a lily pad on time in this age, this universe. Now it

is 6:10 pm it is difficult to write any more. At 6:32 p.m. all I can say this is the very best experience. At 8:25 p.m. I have some ideas I can put down on paper.

The remarkable world of Ketamine

If words could help me more the happier I'd be. If I were to use poetry I would perhaps contribute to the mystery of Ketamine. But this time I know I've been with myself, in this time, totally and in a sense of thanksgiving, and a humble praise to our potential as humans to provide the best evolution possible. The utter diversity and complexity of the mind requires an attitude of dedicated introspection. Within us lies the growth of nature manifesting itself through its constant additions to our ways of thinking. This time I was on many plateaus. One was a glorious radiant and warm plateau with a deep communion with everything. The other plateau was of thoughts inextricably woven into the fabric of the world, and lastly another was seeing my own personal self amongst the world's selves.

The tree in the backyard appeared to be embracing me, and I felt a true sense of oneness with what I was looking at. The sun painted me in liquid gold as I lay on the couch facing west. Indeed, the combination of elements this time was perfectly arranged. I can only wish that my mind has selected those ingredients which made this experience what it was, and guide me in my life so I can share that same vision or feeling with others. More is truly occurring than can be thought about. I can only apologize for not saying more. Perhaps as I meet people my own personal energy will be felt and act as an indicator of my awareness of sensitivity to this new world of consciousness within all of nature.